

# CHAPTER 1 - Introduction

---

## **1.1 A few facts about LyTec™ Wires**

LyTec™ Wires are a breakthrough in electroluminescent light technology. For the first time, electroluminescent light has been applied in a linear form, free from the limitations of flat surfaces.

LyTec™ Wire is a world-wide patented, unique linear light which can be produced in continuous form and cut and shipped by the user.

LyTec™ Wire is thin, flexible, durable, non-toxic, safe, UV resistant, uses minimal electricity, available in a wide range of colors and more...

ELAM's innovative LyTec™ Wires have a wide ranging variety of applications through industrial, safety and decoration products to mass market in individual consumers.

More applications..... The sky is the limit !

## **1.2 Electroluminescent Technology Background**

The discovery of Electroluminescent (EL) phosphor is credited to George Destrian while working at Madam Curie's Paris laboratory in 1936. Destrian began his investigations after a lab technician accidentally noticed that zinc sulfide was sensitive to electrical fields. The technology slowly progressed, but it wasn't until recently that EL became a reliable alternative to conventional lighting methods.

## **1.3 About ELAM Electroluminescent Industries Ltd.**

ELAM Electroluminescent Industries Ltd. (ELAM IND.), a private young and dynamic company, driven by a team of experienced physicists and engineers, was established in 1994 after a long research and development program culminated in a technological breakthrough involving Electroluminescent Wires.

Elam's current product group of Electroluminescent wires LyTec™ is a newcomer to the lighting world because of being unique as the only linear and flexible light source available in small diameters (2.3 mm/0.09") and in a variety of colors.

In developing an innovative world-wide patented electronic component - LyTec™ , ELAM has also developed an unique production technology and automatic machinery line with a capacity of more than thousands of kilometers per year.

To house the production lines, a 3100 sq. meters (33.500 sq. ft) plant was based in Har-Hotzvim, the newest Hi-Tech complex in Jerusalem.

ELAM's marketing strategy is based on three phases:



1. Establishment of a world-wide network supported by representatives/agents.
2. Supporting customers and OEM's designers for designing of new applications and products which incorporate LyTec™ Wires.
3. Marketing LyTec™ Wire to OEM's and to distributors who stock inventory to supply users.

ELAM - U.S.A. Inc. a marketing subsidiary of ELAM - ISRAEL IND., is responsible for sales in America.

ELAM continues to invest considerable resources to improve new products, process control automation and expected to receive the ISO 9002 certification during 1999.



## 1.4 What's in the Package

Please take some time to get familiar with the parts listed below. If any of those items are missing or damaged, please contact your dealer or shipping carrier immediately. (Commercially available items not included).

Item No.	Qty.	Description	ELAM Cat.	Part No.	Length [m/ft]	Notes
1	1	General Purpose Blue/Green Wire	ELF01S23-BG	ELF01S23-BG	10meters (32.8ft)	with snap-in connector + inverter (see Item No. 16)
2	1	General Purpose Blue/Green Wire	ELF01S23-BG	ELF01S23-BG	3meters (9.8ft)	without connector termination
3	1	General Purpose Green Wire	ELF01S23-G2	ELF01S23-G2	1meter (3.3ft)	with snap-in connector + inverter (see Item No. 13) + battery holder (see Item No. 17)
4	1	General Purpose Yellow Wire	ELF01S23-Y1	ELF01S23-Y1	1meter (3.3ft)	with snap-in connector
5	1	General Purpose Red Wire	ELF01S23-R2	ELF01S23-R2	1meter (3.3ft)	with snap-in connector
6	1	General Purpose Pink Wire	ELF01S23-S1	ELF01S23-S1	1meter (3.3ft)	with snap-in connector
7	1	General Purpose White Wire	ELF01S23-W1	ELF01S23-W1	1meter (3.3ft)	with snap-in connector
8	1	General Purpose Ultra Marine Wire	ELF01S23-UM	ELF01S23-UM	1meter (3.3ft)	with snap-in connector
9	1	Industrial Grade Blue/Green Wire	ELF02I32-BG	ELF02I32-BG	1meter (3.3ft)	with snap-in connector
10	1	Heavy Duty Grade Green Wire	ELF02S32-G3	ELF02S32-G3	1meter (3.3ft)	with snap-in connector
11	1	Heavy Duty Grade Yellow Wire	ELF02S32-Y3	ELF02S32-Y3	1meter (3.3ft)	with snap-in connector
12	1	Heavy Duty Grade Red Wire	ELF02S32-R3	ELF02S32-R3	1meter (3.3ft)	with snap-in connector
13	1	Inverter	81 011 00/1	IFW 2522	up to 1.5meter (4.9ft)	600Hz, AC output with snap-in connector, 3 VDC input with battery clip
14	1	Inverter	81 021 10/1	IFW 3262	up to 3meters (9.8ft)	2KHz, blinking mode, AC output with snap-in connector, 9 VDC input with battery clip
15	1	Inverter	81 023 00/1	ISW 3293-GR	up to 5meters (16.4ft)	400Hz, AC output with snap-in connector, 3 VDC input with battery clip
16	1	Inverter	81 032 00/1	IFW 5541-2K	up to 15meters (49.2ft)	2KHz, AC output with snap-in connector, 9 VDC input with battery clip
17	1	Battery holder	82 101 00			holds 2xAA 1.5VDC batteries
18	1	220 VAC Plug	82 051 01/0		up to 1meter (3.3ft)	fused with surge protection resistor and snap-in connector
19	1	110 VAC Plug	82 052 01/1		up to 1 meter (3.3ft)	fused with surge protection resistor and snap-in connector
20	5	Electrical Cable	82 011 01/1	C63481	20cm (7.8")	UL approved
21	5	Shrink tubing ¼"-MW black	82 031 00/1	CGAT 6/2-0	4cm (1.5")	UL approved
22	10	Shrink tubing 1/8"-MW black	82 041 00/1	CGAT 3/1-0	2cm (0.8")	UL approved

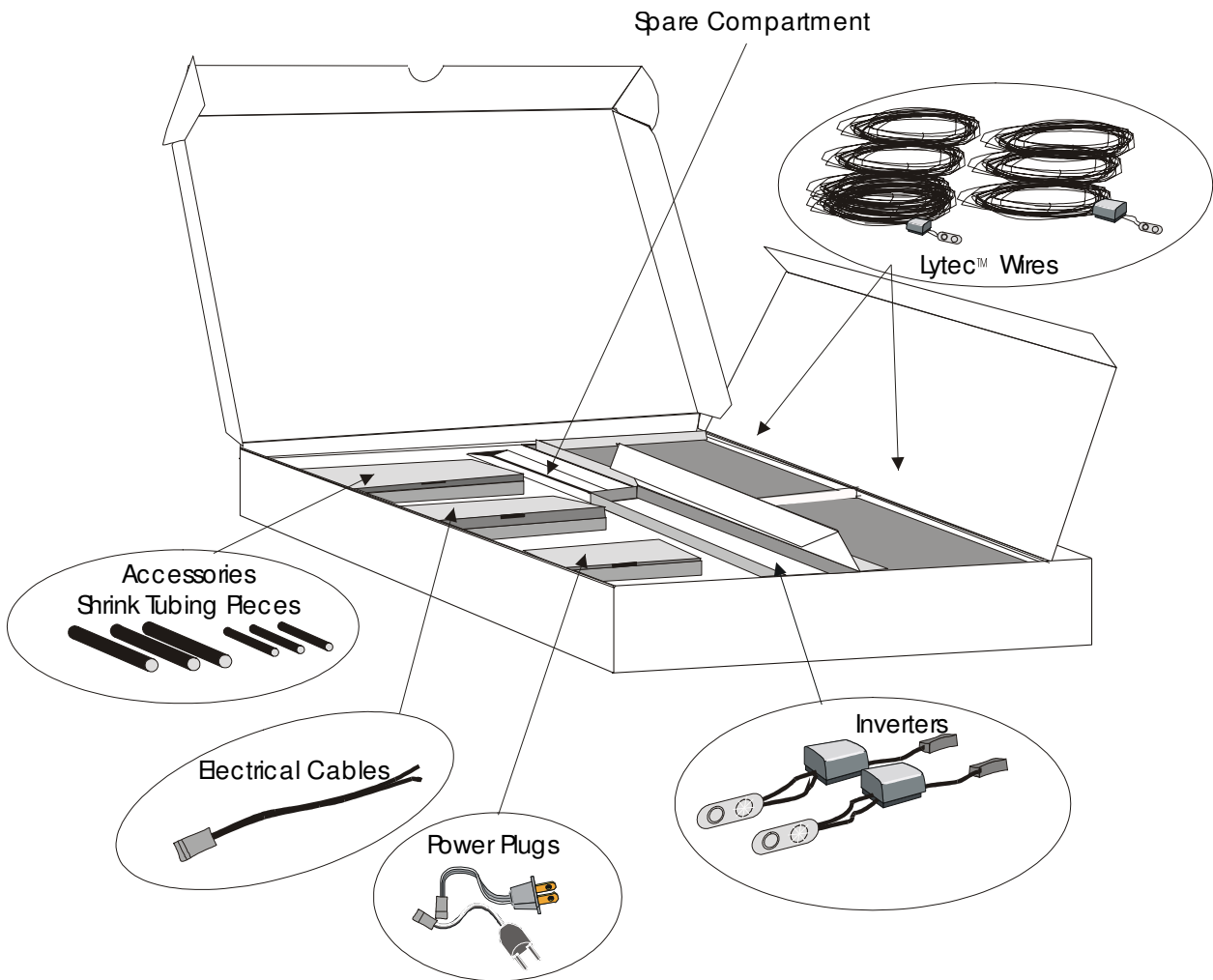

*Figure 1-1: The LyTec™ Wire Design Kit box contents*

## 1.5 Design Kit Parts Description

1. **LyTec™ Wires**: The LyTec™ Wires compartment contains 11 pieces of various lengths and colors of LyTec™ Wires with snap-in connector and one of 3m long piece of Blue/Green wire without snap-in connector. The last one is designed for training of assembly free end terminations and connections as described in Chapter 3. The LyTec™ Wires are classified in three basic LyTec™ Product Groups: General Purpose, Industrial Grade and Heavy Duty Grade.
2. **Power Supplies**: Called also **inverters**, they are designed for driving (powering) various lengths of LyTec™ Wires at different frequencies (i.e. brightness).
3. **110 VAC Power Plug**: Includes a surge protection resistor of 25 k $\Omega$  ...W. The resistor “absorbs” the over voltage in case of spikes or higher voltages than 110 VAC from mains.
4. **220 VAC Power Plug**: Includes a surge protection resistor of 250 k $\Omega$  ...W. The resistor in this case has two functions:
  - Reducing the mains voltage (220 VAC) to 110-120 VAC.
  - “Absorbing” the over voltage in case of spikes or higher voltages than 220 VAC from mains.
5. **Battery Holder**: suitable for 2 x AA 1.5V DC batteries.
6. **Electrical Cables**: It aids to connect between the LyTec™ Wire to power source (inverter or mains). The cable is 22 AWG fully annealed, stranded tinned copper as per ASTM B-33 and UL approved. For assembling instructions please refer to Chapter 3.
7. **Shrink Tubes**: Are designed to isolate the connections between the LyTec™ Wire and the electrical cable, and serve as free end termination of the LyTec™ Wire. For assembling instructions please refer to Chapter 3.

## CHAPTER 2 - Manual Overview

---

### 2.1 Features of the LyTec™ Electroluminescent Wires

The technology behind LyTec™ is complex, and much of it comes from the semi-conductor industry. Electrically, the LyTec™ Wire is a light emitting capacitor. The capacitive structure is developed with the light emitting electroluminescent semi-conductor layer sandwiched between two conductive electrodes.

It consists of a copper wire which serves as a core electrode. The copper wire is coated with several layers of dielectric and semi-conductor materials which together form a coaxial construction. A transparent conductive layer is then added with two thin copper wires which serve as the second electrode and when AC voltage is applied between the two electrodes and exceeds a well-defined threshold value, the semi-conductor material between the two electrodes emits light.

The LyTec™ Wire and its production technology are world-wide patent pending.

ELAM is successfully manufacturing the Electroluminescent Wire in a continuous process. This Wire, basically a plain copper wire is processed through a variety of various stations. With each station adding a specific layer to the surface of the wire.

ELAM uses a highly sophisticated technological process, similar to ones used by semi-conductors manufacturers such as Intel and Motorola, in producing their products.

During the production process, one machine coats the copper wire with a very thin layer which is conductive yet transparent. This process is done using unique vacuum deposition machinery, where a plasma condition occurs. This allows for the continuous processing of the cable light products.

The LyTec™ Wire is flexible, durable and tough and can be twisted into almost any shape or form and cut at arbitrary lengths making it ideal for a wide range of applications. It is elastic in form and comes in a lot of colors. It can dim or flicker, and is also UV resistant.

The product is uniquely cold to the touch while its operation is non-toxic and safe.

The diversity in length of the LyTec™ Wire gives it almost unlimited possibilities and it's efficient and low energy consumption, make it attractive for many applications. It can be operated from 220/110V AC with/without AC to DC Adaptor or from a DC battery source (1.5 - 24V DC).

The LyTec™ Wire is approved by CE, UL and MSHA. Environmental operation conditions and various applications dictate three basic LyTec™ Product Groups. Each product group is made using different construction and design criteria developed for specific needs and requirements. For more detailed technical data sheets see Chapter 5 – LyTec™ Wires Classifications.



## **2.2 Main Applications of LyTec™ Wires**

**Safety** - Applications are varying from safety jackets/belts for policemen and night workers, guiding lights at subways, traffic tunnels and landing pads to automotive applications as traffic signs, etc.

**Signage** – The LyTec™ is an excellent solution and has a significant cost advantage over current technologies for use in advertising signs in dark and semi-dark environments such as pubs, restaurants, trade-shows and Points of Sale. Also, its elasticity with its range of colors makes it an “eye catcher” product and attractive for ornament applications, gift and fashion items.

**Military** – The LyTec™ is used to mark minefields, restricted and/or forbidden areas and landing pads for helicopters.

**Decoration** – The LyTec™ is used for ornaments (Christmas trees, toys, parades, etc.), car accessories (indoor and outdoor car decoration) and fashion (fashion shows, sneakers and fashion accessories like bracelets and illuminated jewelry).

**Automotive** – The LyTec™ can be used for indoor car decoration (after sales), running board edge lighting, contour lighting for trains and trams, etc.

For more applications please refer to Chapter 6 - LyTec™ Wire General Applications.

## **2.3 Advantages of LyTec™ Wires**

- The only linear light source available in small diameters and unlimited lengths.
- Emits a beautiful 360° uniform color throughout the entire length (up to 800 ft.).
- Non-toxic and safe product, cold to the touch and durable.
- Totally flexible, it can be twisted, bent and cut to any length.
- Available in a wide range of colors.
- Operates directly from a 110V/60Hz or 220V/50Hz power source, and uses less than 0.1 miliamps per foot.
- 1,000 meter (3280 ft) of LyTec™ Wire consumes only as much energy as one 100Watt light bulb when connected to mains.
- Depending on voltage and frequency applied, LyTec™ Wire has a life expectancy of up to 25,000 hours.
- All the wires are UV resistant.
- LyTec™ is UL recognized component as a sign accessory.
- LyTec™ is CE certified as a lighting cable.
- MSHA (Mining Safety and Health Administration) approved for use in lighting ropes.

## 2.4 LyTec™ Wire Brightness

The output light emitted by the LyTec™ Wire can be measured in terms of radiometric or photometric quantities.

Radiometric quantities measure the total light output power of the Wire, regardless of wavelength. However, the human eye is not able to sense all wavelengths.

Therefore, LyTec™ Wire brightness is usually specified in terms of photometric units, which account for the eyes sensitivity. Values of brightness are usually given in units of Foot-Lambert/m<sup>2</sup> - [lm/m<sup>2</sup>] or Nit i.e. Candela/m<sup>2</sup> - [Cd/m<sup>2</sup>] , etc.

The LyTec™ Wire's brightness may be varied by changing the voltage and/or frequency.

The brightness level of such Electroluminescent Wires makes them ideal for indoor or outdoor dark and semi-dark environment applications.

For typical initial brightness level of Blue/Green LyTec™ Wire, please refer to Table 2-1, where you can see the relation between brightness versus voltage & frequency.

Voltage [Vrms]	FREQUENCY [Hz]								
	200	400	800	1000	2000	4000	6000	8000	10000
40	1	3	5	5	8	8	9	9	10
60	6	12	19	21	30	32	37	40	42
80	15	25	40	46	68	73	83	90	96
100	28	41	68	78	116	128	146	160	175
120	46	62	99	115	170	196	223	245	265

**Table 2-1: Initial Brightness [cd/m<sup>2</sup>] of Blue/Green  
LyTec™ Wire versus Voltage & Frequency**

For typical initial brightness level of other colored LyTec™ Wires, please refer to Product Data Sheets in Chapter 5.



## 2.5 LyTec™ Wire Lifetime

Unlike incandescent or fluorescent lamps, the LyTec™ Wire does not abruptly fail. Instead, the LyTec™ Wire brightness will gradually decrease over long periods of use.

Generally, LyTec™ Wire lifetime can be defined in terms of the time it takes the brightness to decrease to 25 - 30% of its initial value under well defined operating conditions. LyTec™ Wire lifetime is affected by voltage, frequency, temperature and humidity.

Increased operating frequency has a greater detrimental effect on a LyTec™ Wire lifetime than increased voltage up to the permitted maximum rating parameters. See attached tables describing LyTec™ Wire lifetime versus various frequencies under constant voltage and humidity. Therefore, lower operating frequencies result in longer LyTec™ Wire lifetime and a flatter brightness decay curve. Depending upon the drive circuit used and the minimum brightness required in the application, the lifetime may be as much as 25000 hours or more, when connected directly to mains (50/60 Hz.).

A sinusoidal waveform is most efficient to power a LyTec™ Wire because it does not have high frequencies elements like: pulses or spikes.

Another strong contributor parameters to shorten the Wire lifetime are: humidity and temperature, unless special manufacturing processes are employed and/or protective housings are included. Typically, the LyTec™ Wires behave well in lower temperatures. Lifetime generally improves as the temperature decreases while brightness decreases. The MVL-02I Industrial Grade LyTec™ Wire is constructed so as to minimize the effects of humidity on the LyTec™ Wire lifetime. See attached Product Data Sheet of the MVL-02I in Section 5.

Constant Temperature		Constant Humidity	Useful Lifetime
[°C]	[°F]	[H%]	[hrs]
55	131	40	500
40	104	70	1200
30	86	70	2300
20	68	70	3300
-20	-4		8000

**Table 2-2: Useful Lifetime versus Temperature**

**Notes:**

Frequency = 400Hz

Voltage = 120Vrms ;

USEFUL LIFETIME (*)					
Frequency [Hz]	50/60	400	800	2000	4000
Lifetime [days]	3300	950	365	270	100
Lifetime [years]	9	2.5	1	3/4	1/4

**Table 2-3: Useful Lifetime versus Frequency**

(\*) The Useful Lifetime is based upon operation cycles: 6 hours ON, 18 hours OFF - reaching 30% of the initial brightness.

**Notes:**

Voltage = 100Vrms

Room Humidity = 40%

Room Temperature = 25°C

## **2.6 Effect of Duty-Cycle on LyTec™ Wire Lifetime**

The LyTec™ Wire is not adversely effected by ON and OFF cycling as with other technologies. The filaments of incandescent lamps for example, are stressed by repeated turn ON and OFF cycling on which will ultimately cause a catastrophic failure.

The LyTec™ Wire is an electronic component with no filaments or burning elements to stress.

Therefore, repeated turn ON and OFF cycling or even pulsed duty-cycles, do not adversely effect the LyTec™ Wire’s performance. but on the contrary, at lower frequencies ,even an improvement of up to 30% of useful lifetime is achieved.



## 2.7 LyTec™ Wire lifetime improvement with autocompensating inverter

Inevitably, as the brightness of the LyTec™ Wire will decrease during its lifetime, its capacitance will decrease and its resistance will increase. Since the inverter's load will increase, the original output voltage will tend to increase, which in turn will increase the LyTec™ Wire brightness.

There are two ways to improve the LyTec™ Wire lifetime:

1. The use of a serial resistor causes voltage increase as the LyTec™ Wire ages. Therefore, it is recommended to use an inverter with a higher output voltage than the allowed voltage of the LyTec™ Wire and to connect a serial resistor in order to “absorb” the initial “gap” voltage up to 30-50 Vrms of the LyTec™ Wire. Consequently, the LyTec™ Wire stays bright for a longer period of time when powered through an inverter compared to a constant output power supply.
  
2. Self-oscillating inverter reacts to the change of the overall impedance of the aging and provides additional compensation by slightly increased its voltage and frequency over time resulting in a flatter decay curve and a longer useful lifetime of the LyTec™ Wire. The use of a self-oscillating inverter may increase the useful Lifetime of the LyTec™ Wires up to 50 - 70% .

<b>VS</b> <b>[Vrms]</b>	<b>Frequency</b> <b>[Hz]</b>	<b>R1*</b> <b>[KΩ]</b>
150	400	34
150	800	17
150	2000	6.7

**Table 2-4: Serial resistor value versus various frequencies.**

- ❖ The value of R1 is for 1 m (3.3ft) LyTec™ Wire long. For longer LyTec™ Wire please consult ELAM Customer Service

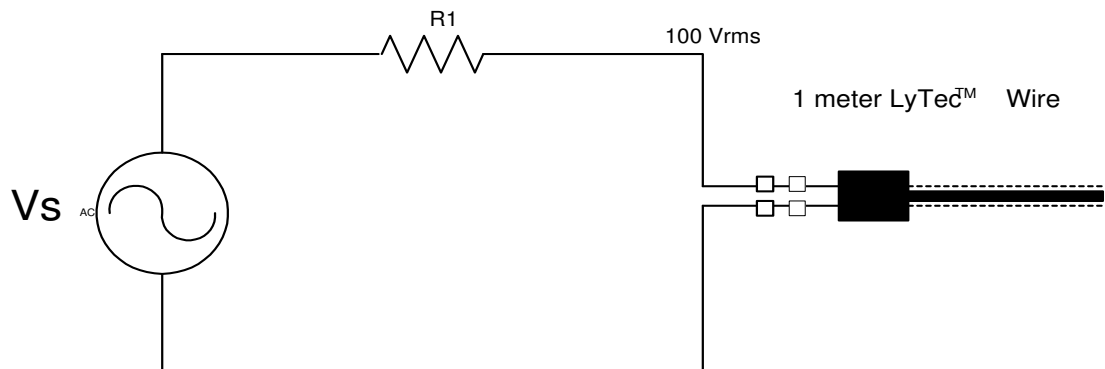

**Figure 2-1: LyTec <sup>TM</sup> Basic circuit using a serial resistor (R1) for lifetime improvement.**



## **2.8 Handling Instructions**

### **2.8.1 Mechanical**

1. Repetitive bending of LyTec™ Wire for a diameter of less than 12.5 mm (4.92”) (5 times diameter of Wire) is not allowed.
2. Mechanical stress - maximum pulling tension 1Kg.
3. Twisting angle - maximum 30° per meter.
4. It is recommended good termination connections according to Chapter 3 – in order to assure long lifetime and avoids penetration of humidity which can affect the semi-conductor layer; therefore the brightness will decrease faster and the LyTec™ Wire life time will be shortened.

### **2.8.2 Electrical**

1. Average AC Current Limit = 100 mAmp.
2. Excessive currents heat the thin wires. At high average currents, blinking will help to maintain good visibility without exceeding the spec.
3. Avoid High Voltage Transients – can cause internal short circuits.

## **2.9 Parts and Functions**

### **2.9.1 Inverters**

The LyTec™ Wire which includes an electroluminescent semi-conductor material, requires an AC power supply for operation. The simplest way to operate the LyTec™ Wire is to connect to mains: voltage of 110Vrms and frequency of 60 Hz.

There are many alternatives for powering the LyTec™ Wires with the required AC power, even if the application currently uses DC power or a higher brightness is required than the one achieved from the mains.

A simple device called **inverter** should be used to convert DC into AC power for battery powered application.

A multitude of brightness can be achieved by adjusting the voltage and/or the frequency in the operational field values. Increasing the frequency will increase the LyTec™ Wire brightness. However, increasing the voltage and frequency reduces the Wire lifetime.

Inverters are commercially available with input ranging from 1.5 to 24 V DC.

When properly designed, multiple LyTec™ Wires can be connected in parallel to a single inverter. The LyTec™ Wire works best when powered by a true sinusoidal waveform inverter.

To achieve the greatest efficiency, the inverter must be matched to the characteristics of the LyTec™ Wire. The dynamic capacitance of the LyTec™ Wire is the primary characteristic to consider when specifying an inverter.

Most of inverters are usually designed for a specific application and desired LyTec™ characteristics. Therefore, before choosing the right inverter, the following parameters should be taken in consideration:

- Input DC power available (battery or mains operated).
- LyTec™ Wire length.
- Required LyTec™ Wire brightness.
- Expectant LyTec™ Wire lifetime.

ELAM can provide properly matched inverters and has the technology to assist customers in developing an optimized Electroluminescent lighting system using the LyTec™ Wire. Alternatively, inverters may be purchased through third party vendors.

<b><u>INVERTERS</u></b>								
Item	ELAM Cat. #	Part No.	Operation Mode	LyTec™ Wire Length]		Input Voltage [DCV]	Frequency [Hz]	
				[meter]	[ft]		Short length	Long length
1	81011 00/1	IFW 2522	Continuous	0.5-1.5	1.6-4.9	3	1050	870
2	81021 10/1	IFW 3262	Blinking	1.5-3	4.9-9.8	9	2700	2270
3	81023 00/1	ISW 3293-GR	Continuous	1.5-5	4.9-16.4	3	750	370
4	81032 00/1	IFW 5541-2K	Continuous	8-15	26.2-49.2	9	2400	1670

**Table 2-5: Data Sheet of Inverters in the Design Kit Box**

## CHAPTER 3 – Assembling Instructions

---

### 3.1 Recommended Tools for LyTec™ Wires Assembling

1. Wire-Stripper.
2. Cutter.
3. Flat nose pliers.
4. Welder (up to 30Watts).
5. Heatgun.

### 3.2 LyTec™ Wire Termination

#### 3.2.1 Step 1:

Strip 0.4'' end of outer and inner insulation layers of the LyTec™ Wire.

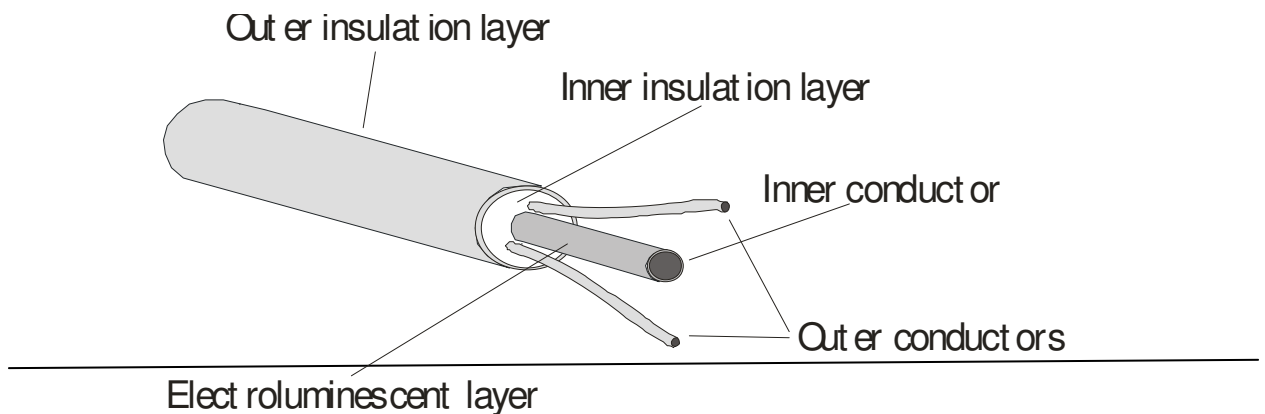

### 3.2.2 Step 2:

Peel back outer conductors and cut them off at the outer insulation step.  
Take a 1/8" shrink tubing (Cat. No. 82 041 00/1) supplied to you and place it over stripped end of the LyTec™ Wire.

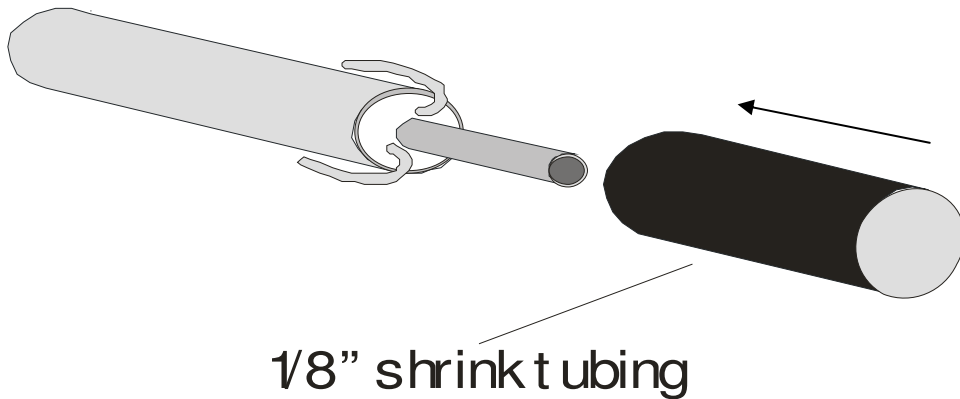

### 3.2.3 Step 3:

Use a heat gun to shrink the tubing.  
Leave a clearance of 0.2-0.4" of shrink tubing over the edge of LyTec™ Wire so that you can clamp it seal tight (against humidity) with a flat plier.

End product should look as follows:

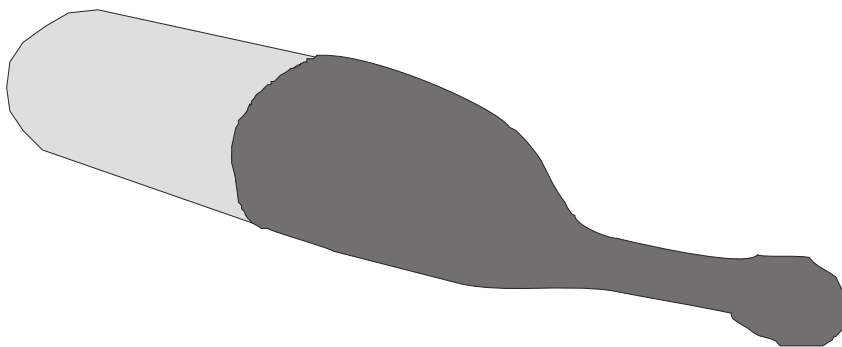

### 3.3 LyTec™ Wire Connection to Electrical Cable

#### 3.3.1 Description of Connecting LyTec™ Wire to Electrical Cable

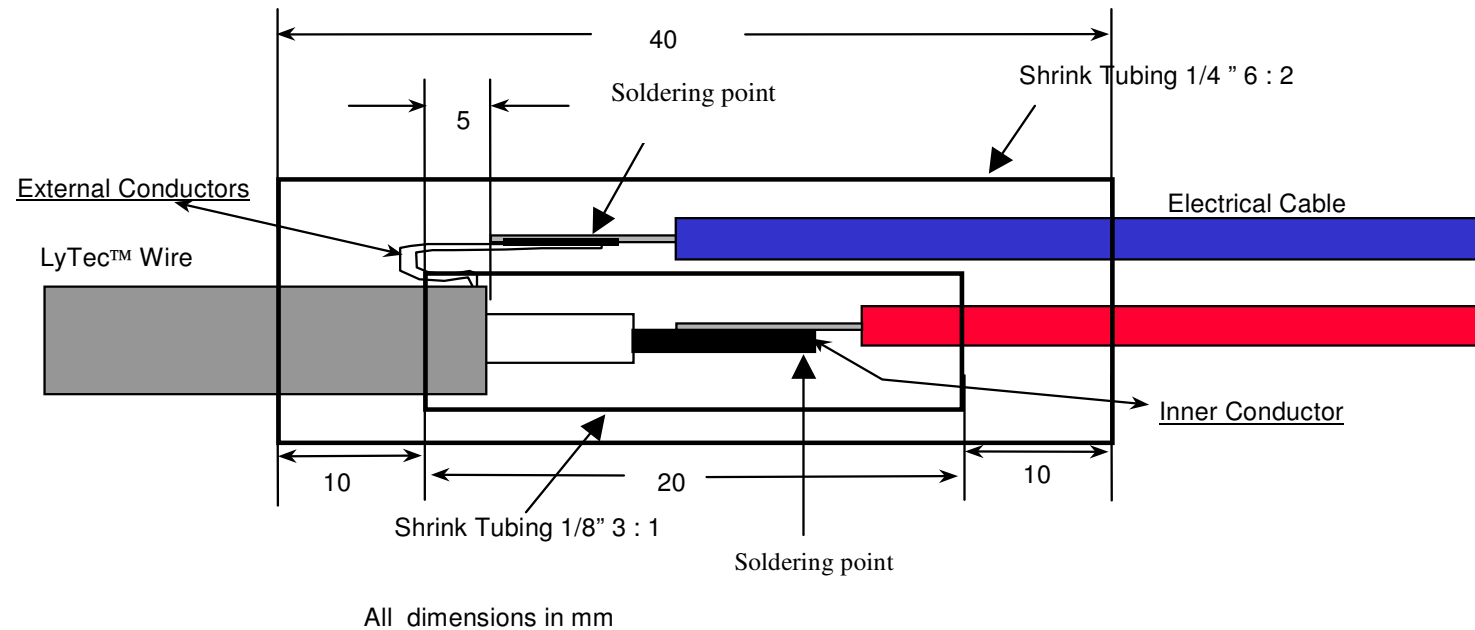



THIS PAGE HAS BEEN LEFT BLANK INTENTIONALY

**3.3.2 Step 1:**

Strip 0.3-0.5'' of outer and inner insulation layers of the LyTec™ Wire.

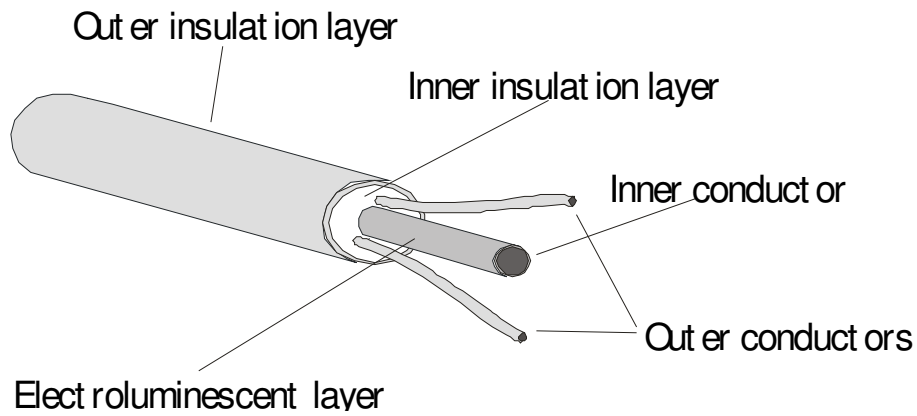

**3.3.2 Step 2:**

Slide a piece of 1/8'' shrink tubing over the electrical cable wires supplied (Cat. No.: 82 041 00/1).

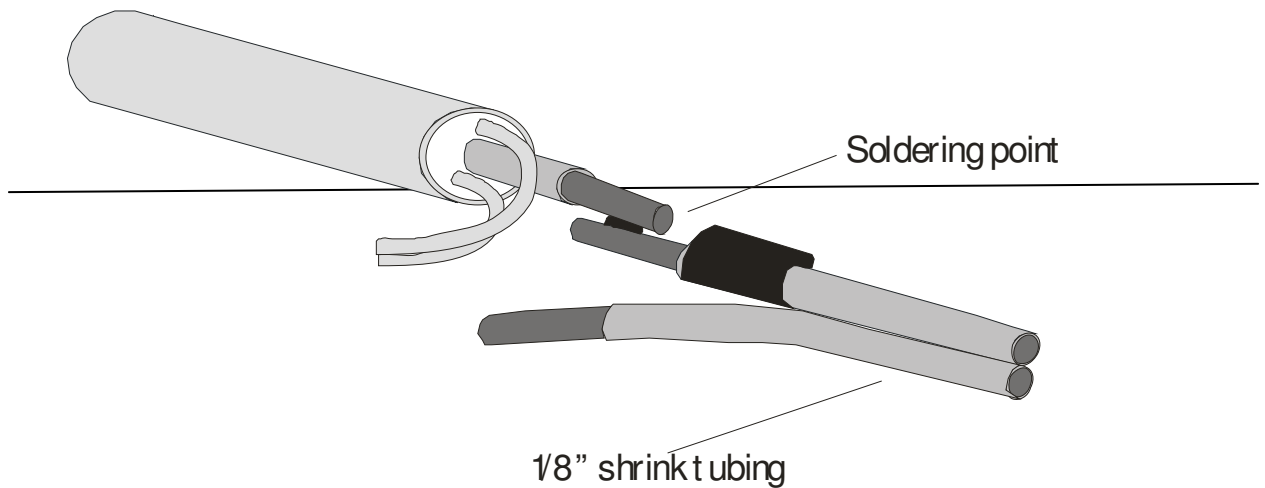

### 3.3.3 Step 3:

Solder the inner conductor of the Lytec™ Wire to that conductor of the electrical cable.

#### **Attention!!**

Soldering of the Lytec™ Wire should be done with minimal use of FLUX or other chemicals.

If, required - use very little FLUX and prevent the FLUX from getting in touch with the LyTec™ Wire's coating layers.

Do not use aggressive - activated FLUX during soldering!!!

It may damage Wire internal layers. Standard core not activated fluxed wire solders are preferred for making the joints.

Slide the 1/8" shrink tubing over the soldered connection, and with the aid of a heatgun shrink the tubing.

The result should look like the following picture:

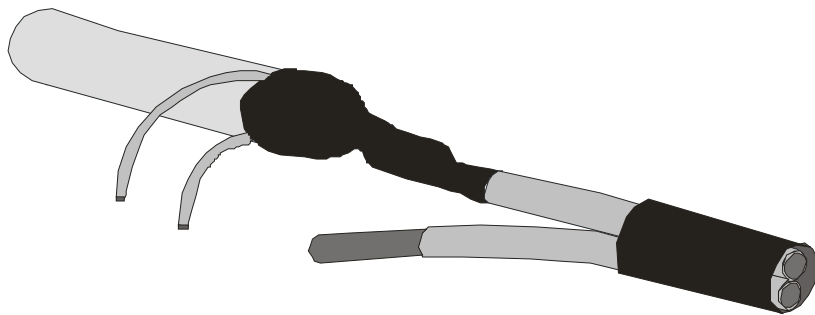

### 3.3.4 Step 4:

Join and twist the two thin outer conductors.

Solder the other lead of the electrical cable to the outer connector of the Lytec™ Wire.

Be careful do not detach them - as they are delicate.

Slide another piece of ¼” shrink tubing supplied (Cat No.82 031 00/1) over the electrical cable.

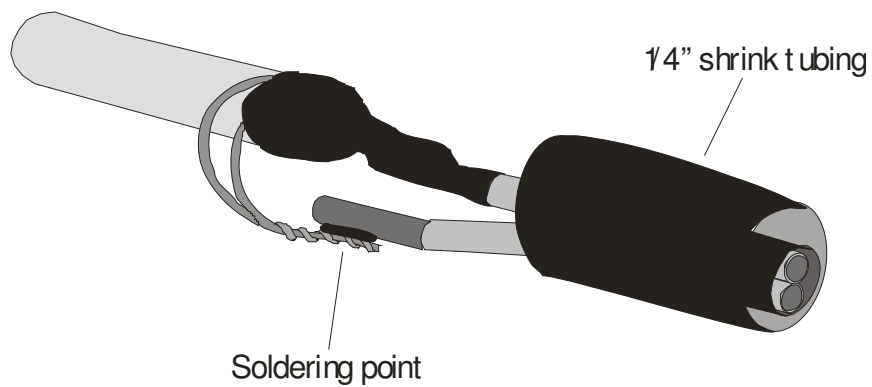

### 3.3.5 Step 5:

Now, again, slide the ¼” shrink tubing over the connection and with the aid of the heat - gun shrink the tubing on top of the connection.

End product should look as follows:

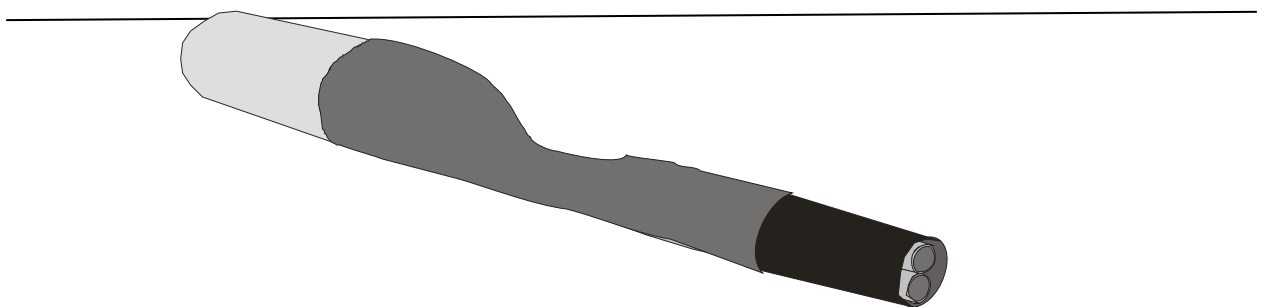

## 3.4 Connecting segments of Lytec™ Wires

### 3.4.1 Step 1:

Strip 0.3-0.5'' of outer and inner insulation layers of the two LyTec™ Wires.

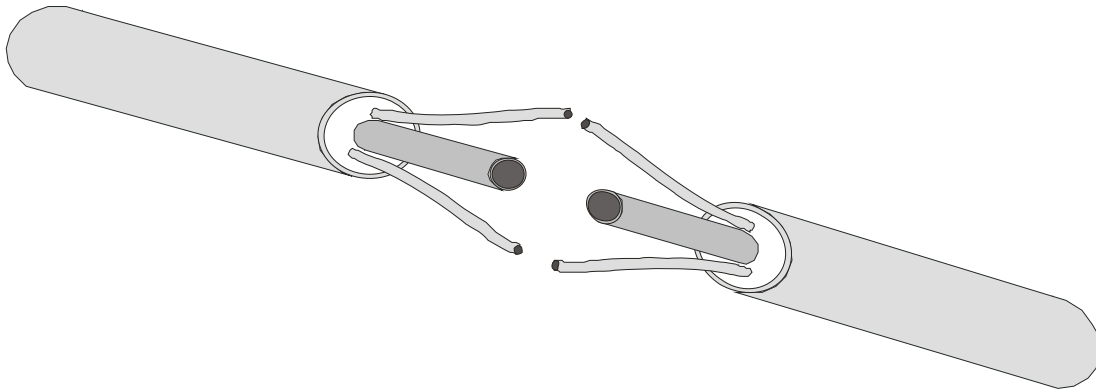

### 3.4.2 Step 2:

Slide a piece of 1/8'' shrink tubing over the inner conductor of the right LyTec™ Wire.

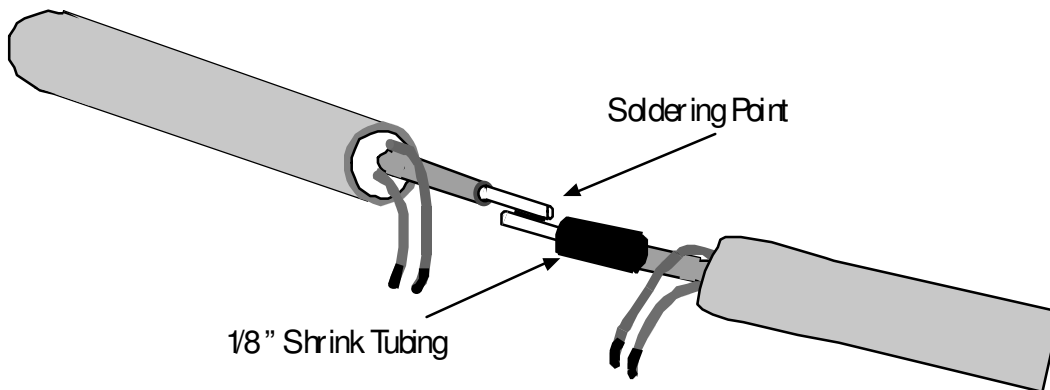

### 3.4.3 Step 3:

Solder the inner conductors of the two LyTec™ Wire.

#### **Attention!!**

Soldering of the LyTec™ Wire should be done with minimal use of FLUX or other chemicals.

If, required - use very little flux and prevent the flux from getting in touch with the wire's coating layers.

Do not use aggressive - activated FLUX during soldering!!!

It may damage wire internal layers. Standard core not activated fluxed wire solders are preferred for making the joints.

Slide the 1/8" shrink tubing over the soldered connection, and with the aid of a heatgun shrink the tubing.

The result should look like the following picture:

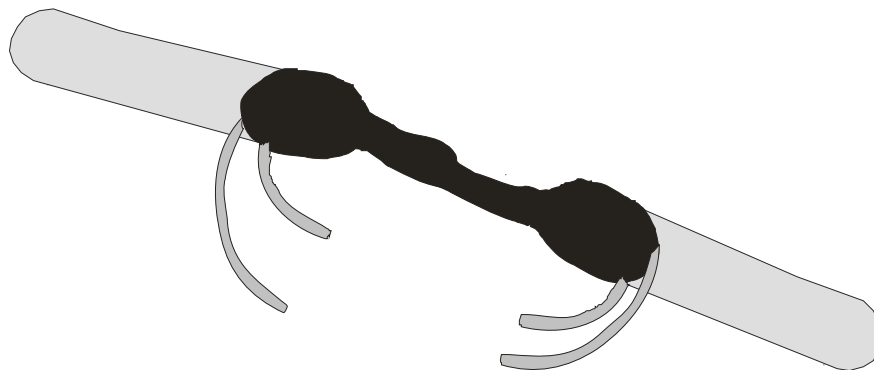

### 3.4.4 Step 4:

Join and twist the two thin outer conductors of the two LyTec™ Wires and solder them. Be careful do not detach them - as they are delicate.

Slide another piece of 1/4" shrink tubing supplied (Cat No.82 031 00/1) over the right LyTec™ Wire.

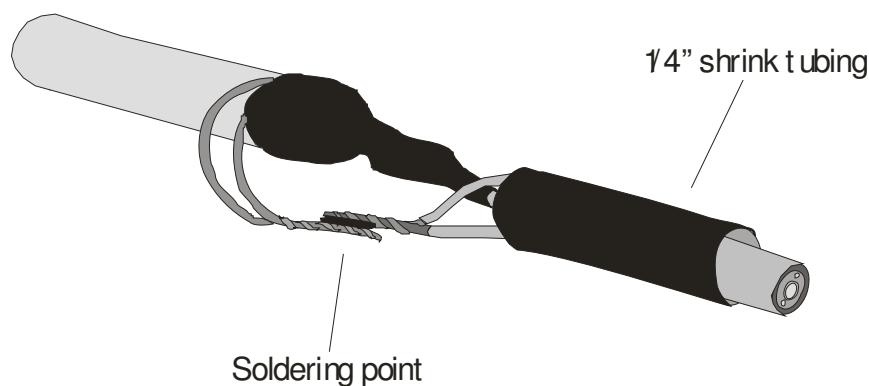

### **3.4.5 Step 5:**

Now, again, slide the 1/4" shrink tubing over the connection and with the aid of the heatgun shrink the tubing on top of the connection.

End product should look as follows:

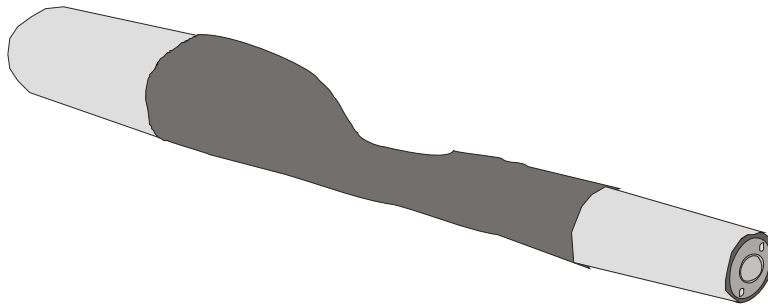

### **Recommended Components:**

- (6) Raychem Shrink Tubing 1/8" CGAT 3/1-0 MW Black
- (11) Raychem Shrink Tubing 1/4" CGAT 6/2-0 MW Black

## CHAPTER 4 – Design Kit Operation Instructions

---

### 4.1 General

Now, after you learned the theory about the LyTec™ Wire and it's accessories and how to assembly it to an electrical cable, etc., it is the time to practice how to operate the Kit's parts by connecting to AC and DC power supply sources.

#### 4.1.1 **Commercially available parts necessary for the first operation of the Design Kit**

1. Batteries (Alkaline type recommended for better performance):
  - a) Two AA 1.5 V DC batteries
  - b) One 9 V DC battery
2. Universal AC to DC Adapter (one of the following options):
  - a) Input voltage: 110 Vrms  
Output voltage range: 3 to 12 Vdc  
Output current (min.): 300 ma
  - b) Input voltage: 220 Vrms  
Output voltage range: 3 to 12 Vdc  
Output current (min.): 300 ma

#### 4.1.2 **Operating LyTec™ Wires of 1 meter (3.3ft) long with Inverter IFW 2522 (Cat. No. 81 011 00/1)**

1. Open the plastic bag labeled ELF01S23-G2 from the LyTec™ Wires Kit's compartment and take out the (Green color) LyTec™ Wire including the attached inverter.
2. Insert 2 x AA 1.5 DC Alkaline Batteries into the battery holder.
3. The inverter starts operating and the LyTec™ Wire will turn-ON. The frequency obtained is 600Hz.
4. For better visibility turn-OFF the lights in the room or dim them to obtain a semi-dark environment.
5. Repeat the above mentioned steps for connecting and testing the other colored 1 meter (3.3ft) long LyTec™ Wires.

#### 4.1.3 **Operating LyTec™ Wire of 10 meter (32.8ft.) long with Inverter IFW 5541-2K (Cat. No. 81 032 00/1)**

1. Open the plastic bag labeled ELF01S23-BG (10m) from the LyTec™ Wires Kit's compartment and take out the LyTec™ Wire including the attached inverter.
2. Connect one 9 V DC Alkaline Battery to the battery clip.



3. The inverter starts operating and the LyTec™ Wire will turn-ON. The frequency obtained is 2 Khz therefore the brightness is much higher than the one mentioned in the previous paragraph.
4. For better visibility, take care of suitable conditions like: contrast, dark or semi-dark environment.

#### **4.1.4 Operating LyTec™ Wire of 3 meter (9.8ft.) long with Inverter IFW 3262 (Cat. No. 81 021 10/1)**

1. Open the plastic bag labeled ELF01S23-BG (3m) from the LyTec™ Wires Kit's compartment and take out the LyTec™ Wire.
2. Follow the assembling instructions mentioned in Chapter 3 in order to prepare:
  - ❖ LyTec™ Wire free end termination.
  - ❖ Connecting the LyTec™ Wire to an electrical cable (Cat. No. 82 011 01/1).
3. Connect the electrical cable (soldered to the LyTec™ Wire) to Inverter IFW 3262 (Cat. No. 81 021 10/1) output.
4. Connect the battery holder to the 9V DC battery clip of the inverter.
5. Insert two AA 1.5V DC Alkaline batteries.
6. The inverter starts operating in blinking mode and the LyTec™ Wire turns-ON and turns-OFF consequently. The frequency obtained is 2KHz and the brightness is relatively similar to the brightness obtained by Inverter IFW 5541-2K.

#### **4.1.5 Operating LyTec™ Wire of 3 meters (9.8ft.) long with Inverter ISW 3293-GR (Cat. No. 81 023 00/1)**

1. Disconnect the Inverter ISW 3262 from the ELF01S23-BG (3m) which was assembled in subsection no. 4.1.4 of this chapter.
2. Connect the Inverter IFW 3293-GR to the LyTec™ Wire.
3. Connect the 3V DC battery holder (Cat. No. 82 101 00) to the 9V DC clip of the Inverter IFW 3293-GR.
4. Insert two AA 1.5 V DC batteries into the battery holder.
5. The inverter starts operating and the LyTec™ Wire turns-ON. The frequency obtained is 400Hz.

#### **4.1.6 Connecting the LyTec™ Wire directly to 220VAC Outlet**

##### **Precautions:**

- To prevent fire or shock hazard, do not expose the units of the Design Kit to rain because the Kit contains only electric and electronic components which are not designed for outdoor and harsh conditions.
- Make sure that all connections are made before plugging the units to an AC power outlet.

1. Open the Power Plugs compartment in the LyTec™ Wires Kit and take out the 220 VAC Power Plug.
2. Take one of the colored LyTec™ Wires of 1 meter (3.3 ft) long and connect it to the snap-in connector of the 220 VAC Power Plug.
3. Plug the Power Plug to the AC outlet and the LyTec™ Wire will turn ON. The brightness obtained is the lowest because the frequency is only 50Hz.
4. For better visibility, turn OFF the lights in the room.

Note:

The 220 VAC Power Plug includes a surge protection resistor matched for a load of 1 meter (3.3 ft) long LyTec™ Wire.

Connecting a LyTec™ Wire of more than 1 meter (3.3 ft) long to this Power Plug will result in a lower brightness than the one obtained in the previously mentioned paragraph 4.1.6.3.

For connecting LyTec™ Wires longer than 1 meter (3.3 ft) the surge protection resistor shall be changed. Therefore, please consult the ELAM Customer Service.

#### **4.1.7 Connecting the LyTec™ Wire directly to 110VAC Outlet**

1. Open the Power Plugs compartment in the LyTec™ Wires Kit and take out the 110 VAC Power Plug.
2. Take one of the colored LyTec™ Wires of 1 meter (3.3ft) long and connect it to the snap-in connector of the 110 VAC Power Plug.
3. Plug the Power Plug to the AC outlet and the LyTec™ Wire will turn ON. The brightness obtained is the lowest because the frequency is only 60Hz.
4. For better visibility, turn OFF the lights in the room.

Note:

The 110 VAC Power Plug includes a surge protection resistor matched for a load of 1 meter (3.3 ft) long LyTec™ Wire.

Connecting a LyTec™ Wire of more than 1 meter (3.3 ft) long to this Power Plug will result in a lower brightness than the one obtained in the previously mentioned paragraph 4.1.7.3.

For connecting LyTec™ Wires longer than 1 meter (3.3 ft) the surge protection resistor shall be changed. Therefore, please consult the ELAM Customer Service.

## 4.2 Ways of Connecting the LyTec™ Wire

There are various modes for operating the LyTec™ Wire

### 4.2.1 Connecting the LyTec™ Wire directly to mains.

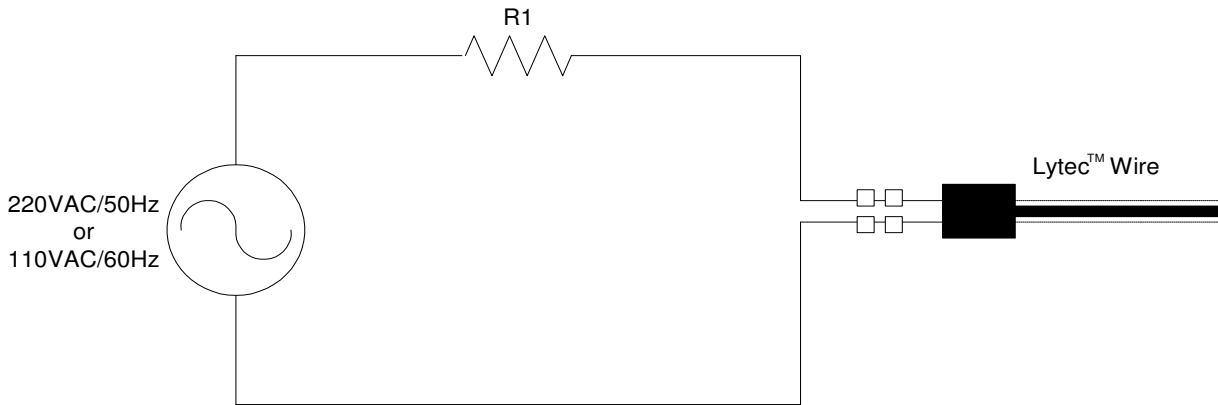

### 4.2.2 Connecting the LyTec™ Wire to an inverter powered by a battery.

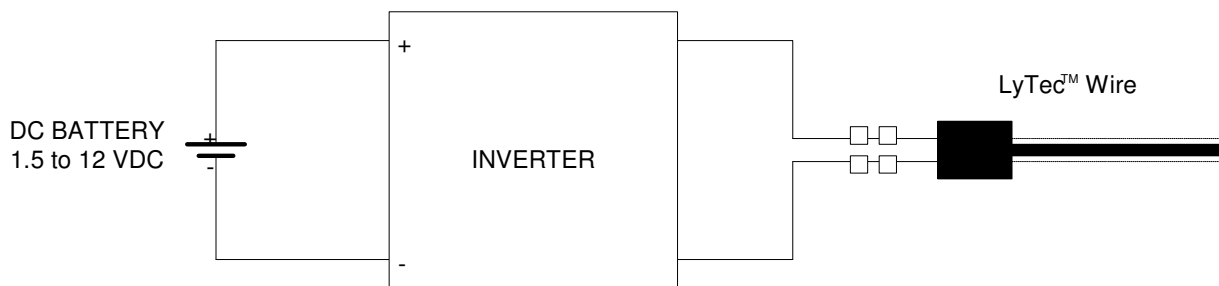

**4.2.3 Connecting the LyTec™ Wire to an inverter powered by mains through an AC/DC adapter.**

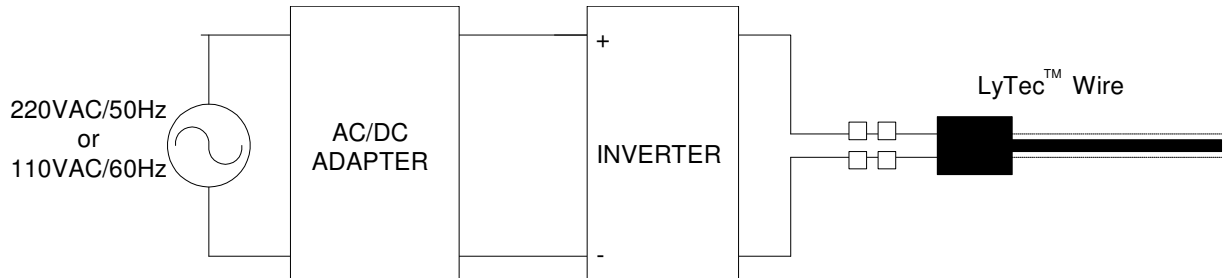

**4.2.4 Connecting the LyTec™ Wire to an inverter powered by rechargeable batteries.**

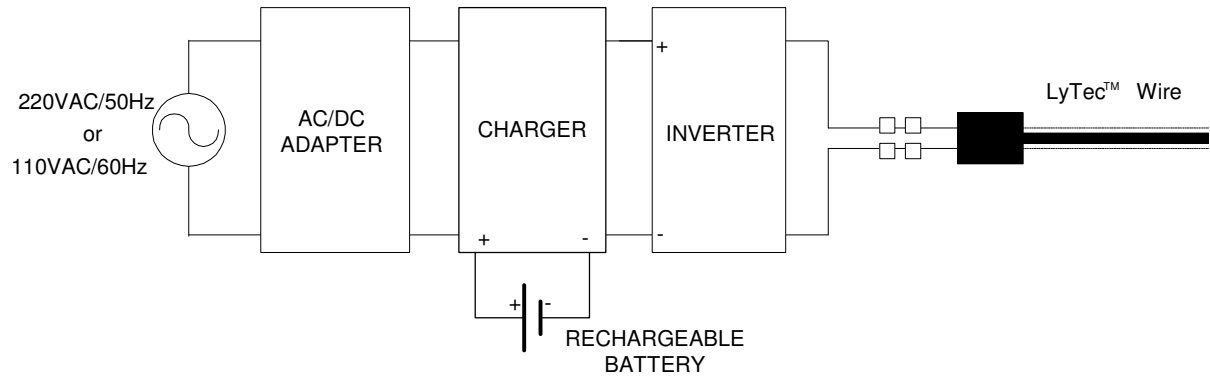



### **4.3 Design Considerations**

Before designing the final product involving Lytec™ Fiber and inverter (or option), the following parameters should be defined first:

1. Environmental operational conditions: indoors/outdoors (humidity, salt, sun radiation exposure).
2. Lytec™ Fiber useful lifetime expectancy.
3. Brightness.
4. Color.
5. Length.
6. Operation mode: continuous/blinking/both.
7. Power supply: battery/mains operated.
8. Power consumption.
9. Battery operational lifetime expectancy.
10. Type of connector (if required).
11. Physical final product size.

This data will aid you in selecting the correct inverter type (when inverter is required):

1. Input/output voltage.
2. Input/output current.
3. Operation frequency.
4. Power consumption.
5. Physical size.

Where a specific application dictates, either in terms of special LyTec™ Wire requirements and the standard inverters are not appropriate, ELAM can provide customized inverters specifically designed for particular applications. This requirement should be identified early in the design process.

## CHAPTER 5 – LyTec™ Wires Classification

---

Environmental operational conditions (indoors/outdoors) and various applications dictated three basic LyTec™ Product Groups. Each product group is made using different constructions and design criteria developed for a specific reason. The optimal LyTec™ Wire for a particular application depends on the applications design requirements.

### 1. **SVL-01S: General Purpose Product**

- ❖ Standard Wire diameter: 2.3 mm.
- ❖ Designed primarily for various indoor/outdoor applications, when outdoor use is limited for certain colors primarily due to discoloration under sunlight.
- ❖ Colors available: Blue/Green, Ultra-Marine, Red, Green, Pink, White.
- ❖ Approvals: UL-Electrical Sign Accessory/Component certification.
- ❖ Product applications:
  - a. Indoor illuminated signs.
  - b. General Purpose decorations.
  - c. Safety lighting.

### 2. **MVL - 02I: Industrial Grade Product Group**

- ❖ Typical Wire diameter: 3.3 mm.
- ❖ Designed for extremely harsh environment.
- ❖ Colors available: Blue/Green, White.
- ❖ Approvals: CE-Lighting Cable category. MSHA-approved for mine application: UL 588 certification in process.
- ❖ Product applications:
  - a. Landing pads.
  - b. Automotive.
  - c. Safety lighting.

### 3. **HVL - 02S: Heavy Duty Grade Product Group**

- ❖ Typical Wire diameter: 3.3 mm.
- ❖ Designed for prolonged outdoor applications.
- ❖ Approvals: CE – Lighting Cable category; UL in process.
- ❖ Available colors: Blue/Green, Yellow, Red, Green, Ultra-Marine, White.
- ❖ Product applications:
  - a. Outdoor signs.
  - b. Markings.
  - c. Lighting applications.

#### **Note:**

LyTec™ Wires that will be subject to an abnormal environment need a special design. ELAM's Customer Support will assist you in making your LyTec™ Wire reliable for your application.

---



## CHAPTER 6 – LyTec™ General Applications

---

The LyTec™ Wires can be used in many different commercial applications which can be categorized in the following sectors (industries): Safety, Military, Automotive, Signage and Decoration.

### 6.1 Safety Applications

The safety applications are characterized with a need for lengthy LyTec™ Wires, long operation time and durability for tough environment conditions. The following are examples of some LyTec™ sectors and applications in the safety industry:

#### ■ **Emergency Escape**

LyTec™ is ideal for emergency escape guidance lighting in mines, tunnels, subway, buildings etc. Using simple electronics and a bread of three LyTec™ Wires can create a “chasing light effect” to show the preferred route in case of emergency. Because the LyTec™ power consumption is very low, it can operate for many hours while connected to a backup power source (batteries, solar panel, generator). Marking aisles and stairs in movie theaters, hotels etc. can avoid major injuries.

Because LyTec™ Wires do not suffer catastrophic failure, there is no need to replace them, eliminating costly light bulb maintenance and replacement costs.

#### ■ **Personal Safety**

LyTec™ can be crucial for marking dangerous areas in roads such as accident spots, road works, deep pits, sharp turns, rocks avalanche etc. Because the LyTec™ is very flexible, it can be very easily sewed into safety attire (road workers vests belts, jackets and coats for police, ambulances, road patrols and fire department), thus making them visible from a long distance (well before reflector strips return the light). The same applies for marking pedestrians, bicycles, rollerblades, skateboards, sneakers and school bags / backpacks.

#### ■ **Aviation**

LyTec™ can be used to mark helicopter landing systems and obstacles near the airplanes landing path like high buildings, antennas, water towers, high voltage lines, etc. (a test demonstrated that a bread of LyTec™ Wires can be seen from thousands of feet). It can also show the correct direction while taxiing to/from the parking area.



## 6.2 Signage Application

The LyTec™ Wire is the new revolutionary neon like lighting component for signage. LyTec™ Wire flexibility allows sharp bending angles for fine graphic designs and thin profile signs. Additional advantages like low weight, low power consumption (portable battery operation possible), user programmable animation and wide range of colors make the LyTec™ Wire ideal for the following low cost applications:

- Custom made signs : restaurants, pubs, cinema theaters, museums, ranches, etc.
- Promotion signs
- Exhibitions / trade shows
- Point of Sales
- Vehicle mounted signs
- Do it yourself signs

The LyTec™ Wire is a very good solution to enhance the visibility of traffic signs such as STOP sign, warning triangle signs, street name signs and even airborne dragged signage.

## 6.3 Decoration Application

The decoration applications usually need short pieces (up to a few meters) of LyTec™ for ornaments / fashion and medium pieces (up to a few tens of meters) of LyTec™ for street decoration. The following are examples of some LyTec™ sectors and applications in the decoration industry:

### ■ Ornaments

The elasticity of the LyTec™ along with its various colors makes it a “eye catcher” product and attractive for ornament applications or gift items. Examples are the movie settings, private houses decorations (indoor and outdoor), Christmas trees, parades, toys, souvenirs and “Kitsch & Gadgets”.

### ■ Fashion

The LyTec™ Wire can fit into fashion items like costumes (Halloween and Carnivals), evening wear, sports clothes, sneakers, discotheques wear and fashion shows/extravaganza. The LyTec™ Wire can be applied in a wide range of fashion accessories like: hair accessories, bracelets and illuminated jewelry.

### ■ Car Accessories

The LyTec™ Wire is used for indoor car decoration (dashboard , speakers, etc.) and outdoor car decoration (license plate lighting, trains and trams contour lighting, etc.).



## **6.4 Military Application**

The LyTec™ Wire can be used to mark minefields, prohibited areas and evacuation routes. A small portable kit using the LyTec™ Wire can mark landing areas for helicopters and planes. The LyTec™ Wire in different colors can be used to identify different forces during military exercises when installed on helmets and belts.

## **6.5 Automotive Application**

The LyTec™ Wire is used for applying in running board edge – lighting, etc.